



ECCOTARP HazMat

# Collapsible Spill Berm RAIL



INSTRUCTIONS FOR USE

US



This document describes the operation and characteristics of the Collapsible Spill Berm RAIL (hereinafter „berm“). It contains important information about how to use the berm properly and how to increase its reliability and life. This document must always be available in the place where the berm is used. Keep it together with the berm at all times. The operator is responsible for using the berm safely and in compliance with the instructions in this manual, which applies to any third persons as well. If you have any doubts about the correct use of the berm, please contact the manufacturer or an authorized dealer.

The Collapsible Spill Berm RAIL has a design designed for use in a railway track. The berm is intended for the protection of the environment, people and objects in case of unwanted leakage of dangerous substances from trains and other railway vehicles. The specially shaped structure is developed in such a way that exactly copies the pitch of the track, but at the same time it also enables use without a rail support. The ideal use of the berm is, for example, in accidents on the railway, at railway stations, in the railway depot, when full train tanks are stopped, etc.

## Collapsible Spill Berm RAIL

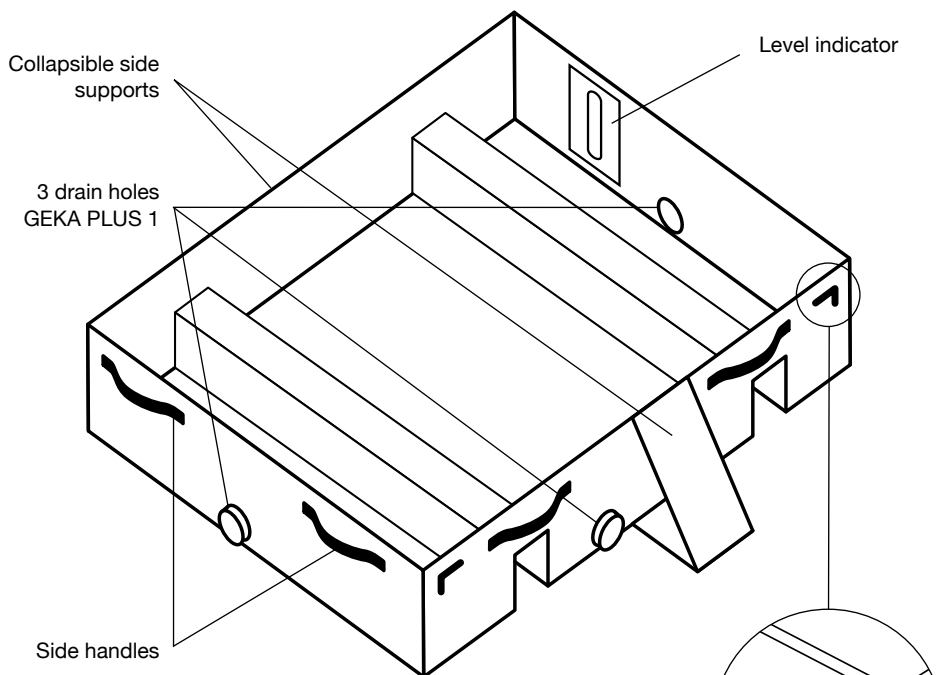

### The delivery includes:

- 1× Collapsible Spill Berm RAIL
- 1× Instructions for use, incl. warranty certificate
- + Optional accessories as per agreement

# Technical details

Type	Dimensions of assembled berm (d × w × h)	Dimensions in transport (disassembled) state (d × w × h)	Volume	Weight
ET RAIL	47.7 × 98.5 × 13 in	36 × 19.7 × 6.7 in	211 gal	26.5 lb

You can find information about accessories on p. 5.

## General information



When using the berms, observe these instructions as well as all the safety notices herein.

1. The berm is designed as a quick solution for emergency situations. It is used to capture dangerous substances leaked from trains and other rail vehicles.
2. The special construction of the berm exactly copies the track gauge of 56.5 in. The berm can be made in different sizes according to individual customer requirements.
3. The construction of the berm is shapeable and adaptable to uneven terrain and other obstacles.
4. The berm is self-supporting. The collapsible side supports ensure greater stability of the berm.
5. The berm is equipped as standard with three GEKA PLUS 1 drain holes.
6. The berm is made of a chemically resistant material – PVC with a protective proofing layer (PES/PVC 1.5 lb/10.7 ft<sup>2</sup>) – see Chemical resistance certificate, p. 7.
7. The berm is not intended for long-term storage of aggressive substances.
8. The range of temperatures for the use of the berms is from -22 °F to +158 °F.
9. Maximum carrying capacity is 441 lb.
10. Maximum volume is 211 gal.
11. Side handles are used to handle the berm.
12. As a standard, the berm is delivered in transport bag.
13. The berm can be fitted with a ball valve D25/other on request.

# Instructions for putting the berm into the ready-to-use position



Take the berm out of the transport bag. Place in on the cleaned surface on the rail and spread the berm on a flat surface. By lifting the sides, securing the corners with yellow hooks and securing the collapsible side supports, the berm is simply created.

## Illustrated instructions for assembly of Collapsible Spill Berm RAIL

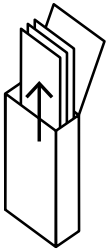

1

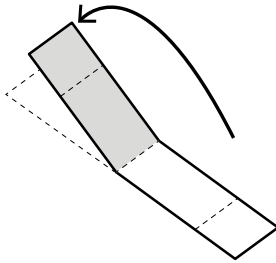

2

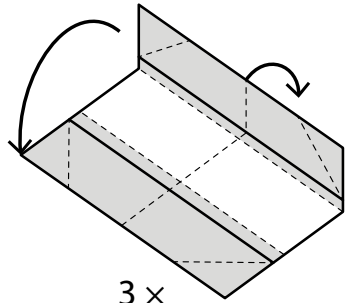

3 x

3

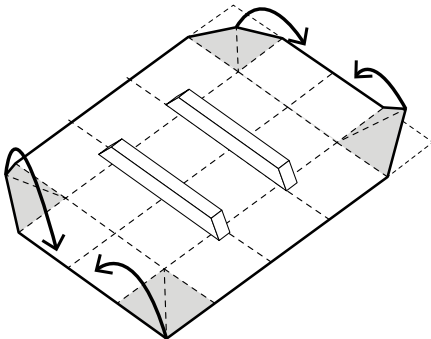

4

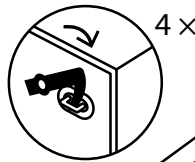

4 x

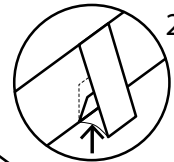

2 x

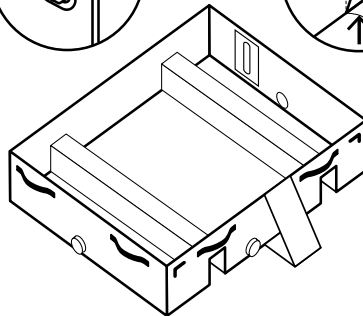

5

# Handling instructions and safety warnings

1. Make sure there are no sharp objects under the berm, such as pieces of broken glass, nails, sharp stones, etc., which might mechanically damage its bottom.
2. Do not put the product near fire or any other sources of heat.
3. The berms are resistant to a large number of different liquids and loose materials (see the Chemical resistance certificate, p. 7).
4. The range of temperatures for the use of the berms is from -22 °F to +158 °F.
5. The berms are not intended for long-term storage of aggressive substances.
6. Fill the berm up only to the upper weld joint of the reinforcement.
7. Do not move or pull an empty or a filled berm on the ground – the manufacturer's warranty does not cover mechanical damage.
8. Use the handling belts to move a filled berm.
9. Make sure not to exceed the maximum volume of 211 gal.
10. After each use it is necessary to wash the berm thoroughly, clean it with suitable detergents and let it dry completely.
11. Observe the safety measures for working with hazardous liquids and with substances harmful to the environment.
12. Make sure you observe any necessary precautions regarding personal safety, such as the use of protective equipment.

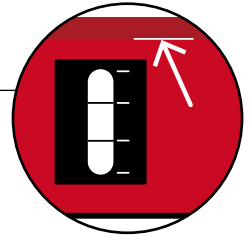

---

## Recommended accessories

The railway berm is delivered in a transport bag as standard. A D25/other ball valve can be added to the berm as an optional accessory for an additional fee.

---

## Maintenance and storage

After the draining and prescribed environment-friendly disposal of the collected substance, the product must be washed with proper neutralization detergent (in the case of aggressive substances) and lukewarm water or another suitable detergent. We recommend storing the berms folded in the carrying bag so that they are not damaged while not in use. The berm must be dried thoroughly before it is put into the bag. For long-term storage, place the berm in a dry place out of the reach of UV radiation.

# Important contact information

Qualified service:

ECCOTARP USA, inc.  
357 West 36th Street  
New York, NY 10018  
USA

info@eccofighter.com

T: 1 212-725-9845

---

## Repair

Any repair work on the railway berm must always be done by the manufacturer's qualified personnel. In the event of unprofessional repair or design change, the product's proper operation cannot be guaranteed. If you want to request repair, order accessories or lodge a complaint, please, contact your qualified supplier.

---

## Warranty conditions

The warranty period is indicated in the warranty certificate on the last page of these Instructions for use.

The warranty period is 24 months and begins on the day indicated in the warranty certificate. The warranty does not apply to the normal wear and tear or to damage caused by improper use or by the instructions in this manual not being observed.

**Warning** – the warranty does not cover damage from long-term exposure to chemicals. This can also occur after the product is improperly cleaned after intervention. Even a small amount of aggressive chemicals will cause degradation of the material from which it is made during long-term exposure. This can be manifested by microscopic cracks on the surface, or by a change in the properties of the material, which can lead to easy damage and tearing.

---

## Disposal

The product must be disposed of in compliance with applicable legal regulations and with the user's internal directives.

# Chemical resistance certificate

Applicable to all types of Collapsible Spill Berms, Tanks, Funnels, Drip trays and Protective Liners.

## Resistance levels:

- A) resistant
- B) resistant for at least 3 hours
- C) non-resistant

Name of substance	Chemical formula	Resistance level at the temperature of 68 °F	Resistance level at the temperature of 140 °F	Name of substance	Chemical formula	Resistance level at the temperature of 68 °F	Resistance level at the temperature of 140 °F				
<b>LIQUID SUBSTANCES</b>											
Acetone	CH <sub>3</sub> COCH <sub>3</sub>	C	C	Hydrogen sulphide	H <sub>2</sub> S	A	B				
Acetonitrile	CH <sub>3</sub> CN	A	A	Styrene	C <sub>8</sub> H <sub>8</sub>	A	A				
Ammonia	NH <sub>3</sub>	A	A	Pentane	C <sub>5</sub> H <sub>12</sub>	A	A				
Benzene	C <sub>6</sub> H <sub>6</sub>	B	B	Toluene	C <sub>6</sub> H <sub>5</sub> CH <sub>3</sub>	C	C				
Tar	mixture	C	C	Salt water		A	A				
Dimethyl-formamide	C <sub>3</sub> H <sub>7</sub> NO	A	A	Water	H <sub>2</sub> O	A	A				
Ethanol	C <sub>2</sub> H <sub>5</sub> OH	B	B	Hydrogen peroxide	H <sub>2</sub> O <sub>2</sub>	A	A				
Ethylene glycol	C <sub>2</sub> H <sub>6</sub> O <sub>2</sub>	B	B	Kerosene	C <sub>9</sub> -C <sub>16</sub>	B	B				
Ethyl acetate	C <sub>4</sub> H <sub>8</sub> O <sub>2</sub>	C	C	<b>SOLID SUBSTANCES</b>							
Ethylbenzene	C <sub>8</sub> H <sub>10</sub>	A	A	Ammonium acetate	CH <sub>3</sub> COONH <sub>4</sub>	A	A				
Formaldehyde	CH <sub>2</sub> O	B	B	Borax	Na <sub>2</sub> [B <sub>4</sub> O <sub>5</sub> (OH) <sub>4</sub> ]-8H <sub>2</sub> O	A	A				
Chlorine	Cl <sub>2</sub>	C	C	Sugar	mixture	A	A				
Chloroform	CHCl <sub>3</sub>	C	C	Potassium cyanide	KCN	A	A				
Transformer oil		A	A	Ammonium nitrate	NH <sub>4</sub> NO <sub>3</sub>	A	A				
Gear oil		B	B	Calcium nitrate	Ca(NO <sub>3</sub> ) <sub>2</sub>	A	A				
SAE 40 oil		A	A	Phenol	C <sub>6</sub> H <sub>5</sub> OH	B	B				
Lubricating oil		A	A	Ammonium phosphate	(NH <sub>4</sub> ) <sub>3</sub> PO <sub>4</sub>	A	A				
Silicone oil		A	A	Potassium nitrate	KNO <sub>3</sub>	A	A				
Turpentine distillates		B	B	Potassium	KOH	A	A				
Hydrochloric acid	HCl	B	B	Sodium hydroxide	NaOH	A	A				
Nitric acid	HNO <sub>3</sub>	B	B	Ammonium chloride	NH <sub>4</sub> Cl	A	A				
Phosphoric acid	H <sub>3</sub> PO <sub>4</sub>	A	B	<b>OPERATING FLUIDS</b>							
Formic acid	HCOOH	B	B	Gas		B	B				
Acetic acid	CH <sub>3</sub> COOH	A	B	Diesel fuel		B	B				
Sulphuric acid	H <sub>2</sub> SO <sub>4</sub>	A	B	Motor oil		B	B				
Sulphurous acid	H <sub>2</sub> SO <sub>3</sub>	A	B	Methyl tert-butyl ether (MTBE)	C <sub>8</sub> H <sub>18</sub> O	B	B				
Isopropyl alcohol	C <sub>3</sub> H <sub>8</sub> O	B	B	Hydraulic oils		B	B				
Methanol	CH <sub>3</sub> OH	B	B								
Methylene chloride	CH <sub>2</sub> Cl <sub>2</sub>	C	C								
Sodium chloride solution 20%	NaCl	A	A								
Mercury	Hg	A	A								

## Notice:

Eccotarp collapsible products are compatible to varying degrees with the substances listed above.

However, given the almost unlimited number of potential combinations of chemicals plus the influence of factors such as concentration and temperature, this list does not claim to be definitive and is only intended for informative purposes in predicting the behavior of the chemicals concerned.

Compatibility with the listed substances cannot be entirely guaranteed. Neither the manufacturer nor the distributor provides any warranty, nor do they accept any responsibility for resultant damage.

For a reliable estimate of the level of resistance to a specific substance, we recommend you to test small samples using miniature laboratory funnels which can be provided upon request by the manufacturer.



The Eccotarp collapsible products are not intended for long-term storage of retrieved spilt liquids. They were developed first and foremost for rapid use in emergencies, for capturing hazardous substances during the time immediately before its correct disposal.

# Warranty Certificate



**This product is guaranteed for 24 months.**

## **This warranty covers:**

for defects caused by a manufacturing defect of the material used, in particular a leak at the welds, a defect in the fittings and any other damage, not caused by demonstrable mishandling by the user or any modification of the product.

## **This warranty does not cover:**

damages caused by improper handling and use of the product and failure to follow the "user manual". For example, punctures or other damage caused by placing the product in an inappropriate area with sharp objects, use or placing the product near open flames, and other inappropriate uses.

**Warning** – the warranty does not cover damage from long-term exposure to chemicals. This can also occur after the product is improperly cleaned after intervention. Even a small amount of aggressive chemicals will cause degradation of the material from which it is made during long-term exposure. This can be manifested by microscopic cracks on the surface, or by a change in the properties of the material, which can lead to easy damage and tearing.

## **The manufacturer is not liable for direct or indirect damage caused by other than the recommended use of the product.**

Complaints must be applied within 24 months of purchase from your supplier. When applying please provide your complaint with full details – product serial number, proof of purchase, appropriate photographic documentation and a detailed description of the circumstances in which a fault has occurred.

Product name:

.....

Production code:

.....

Stamp and signature:

.....

Date of sale:

.....

In case of problems, please contact:

.....

Failure description:

.....

.....