

FOLDABLE DISPENSER CART SDC 03



**INSTRUCTIONS
FOR USE**

EN



Folding Drop Spreader SDC 03 is a tool for spreading any kind of granular sorbents up to 8 mm grain size. From heavy to light mineral granules, including shredded fibrous biological materials. The Drop Spreader allows perfectly smooth flow and density control of the drop with up to 440 mm spreading width.



Attention!

This product is not intended for use with abrasive materials and spreading salt! The cart must be cleaned after each use.

Sturdy design of the wheel hub made of AlMgSi alloy with a flexible tread is designed to achieve optimal vibrant effect. Resistant to oil and chemical substances

Powder coated steel hubcap of the wheel mechanism is sealed with a rubber gasket

The wheel mechanism is fitted with two industrial quality dustproof ball bearings

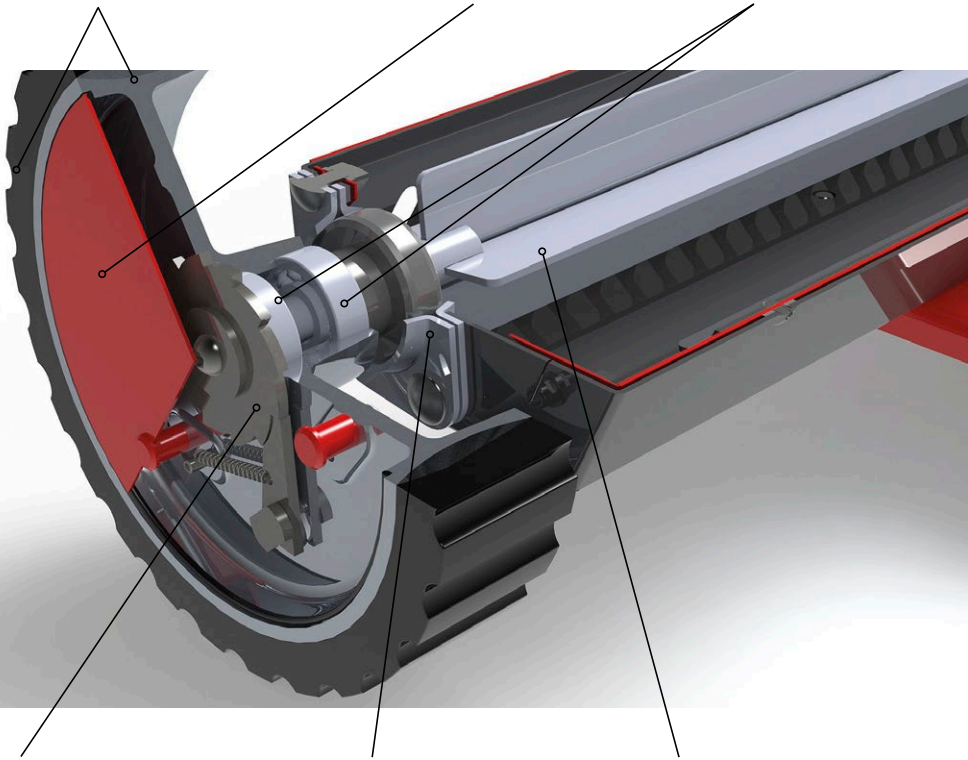

All freewheel drive components are made of durable heavy-duty stainless steel (500 MPa)

A steel bearing unit helps perfect adjustment of smooth operation. The drive shaft is made of high strength steel

The durable stainless-steel self-aligning agitator prevents clogging and contributes to smooth operation

Weight: 13 kg
Hopper capacity: 40 kg
Pack size: 620 x 190 x 750 mm

The folded Drop Spreader takes up only 0,09 m³ of space (620 x 750 x 190 mm), the unfolded **Spreader hold up to 65 l** of material. Working volume without a handle is 0,2 m³, which means more than **100 % reduction of the working volume.**



The Drop Spreader is also available in an unfolding hopper version SDC 05.

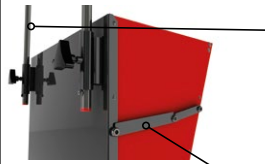

Adjustable handle sliding in the range from 750 to 1300 mm with a stop that prevents full extension. Made of AISI 304 stainless steel, with plastic coated grip.



Hinged side brace ensures safe opening of the hopper or its folding to minimal dimensions.

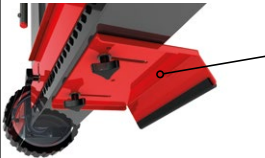

Adjustable anchor secures stability of the cart while filling the sorbent without help of another person. In a retracted position it's only 190 mm wide, which is also the width of the cart folded for storage.



The cart design allows transfer from one place to another with no loss of the sorbent. Application of the material is highly effective because spreading is only enabled when the cart is being pushed forward, backing automatically prevents the drop of the material.



The sorbent is distributed evenly at a chosen application rate using an active agitator inside the hopper.



The spread density control and a spreading width up to max. 440 mm using the profiled spreader plate and two adjusting nuts.



Chemical resistance certificate

Applicable to Foldable Dispenser Carts.

Resistance levels:

A resistant

B resistant for at least 3 hours

C non-resistant

NAME OF SUBSTANCE	CHEMICAL FORMULA	RESISTANCE LEVEL AT THE TEMPERATURE OF 20 °C	RESISTANCE LEVEL AT THE TEMPERATURE OF 60 °C
LIQUID SUBSTANCES			
Acetone	CH ₃ COCH ₃	C	C
Acetonitrile	CH ₃ CN	A	A
Ammonia	NH ₃	A	A
Benzene	C ₆ H ₆	B	B
Tar	mixture	C	C
Dimethylformamide	C ₅ H ₉ NO	A	A
Ethanol	C ₂ H ₅ OH	A	A
Ethylbenzene	C ₈ H ₁₀	A	A
Formaldehyde	CH ₂ O	B	B
Chlorine	Cl	C	C
Chloroform	CHCl ₃	C	C
Transformer oil		A	A
Hydrochloric acid	HCl	A	A
Nitric acid	HNO ₃	A	B
Phosphoric acid	H ₃ PO ₄	A	B
Formic acid	HCOOH	B	B
Acetic acid	CH ₃ COOH	A	B
Sulphuric acid	H ₂ SO ₄	A	B
Sulphurous acid	H ₂ SO ₃	A	B
Methanol	CH ₃ OH	A	A
Mercury	Hg	A	A
Hydrogen sulphide	H ₂ S	A	B
Styrene	C ₈ H ₈	A	A
Pentane	C ₅ H ₁₂	A	A
Toluene	C ₆ H ₅ CH ₃	A	A
Hydrogen peroxide	H ₂ O ₂	A	A
SOLID SUBSTANCES			
Ammonium acetate	CH ₃ COONH ₄	A	A
Borax	Na ₂ [B ₄ O ₅ (OH) ₄] ₂ ·8H ₂ O	A	A
Sugar	mixture	A	A
Potassium cyanide	KCN	A	A
Ammonium nitrate	NH ₄ NO ₃	A	A
Calcium nitrate	Ca(NO ₃) ₂	A	A
Phenol	C ₆ H ₅ OH	B	B
Ammonium phosphate	(NH ₄) ₃ PO ₄	A	A
Potassium nitrate	KNO ₃	A	A
Potassium	KOH	A	A
Sodium hydroxide	NaOH	A	A
Ammonium chloride	NH ₄ Cl	A	A

Notice:

Foldable Dispenser Carts are resistant to the substances listed above. However, given the almost unlimited number of potential combinations of chemicals plus the influence of factors such as concentration and temperature, this list does not claim to be definitive and is only intended for informative purposes in predicting the behaviour of the chemicals concerned. Compatibility with the listed substances cannot be entirely guaranteed. Neither the manufacturer nor the distributor provides any warranty, nor do they accept any responsibility for resultant damage. For a reliable estimate of the level of resistance to a specific substance, we recommend you to test small samples using miniature laboratory funnels which can be provided upon request by the manufacturer. Given that it is not always possible to identify and assess the nature of corrosive substances, the manufacturer recommends using the Eccotarp protective liner.

Attention! This product is not intended for use with abrasive materials and spreading salt! The cart must be cleaned after each use.



Foldable Dispenser Carts are not intended for long-term storage of retrieved spilt substances. They were developed first and foremost for rapid use in emergencies, for capturing hazardous substances during the time immediately before its correct disposal.